

DPB Series
500-4300 scfm
Global Air Treatment



GD GARDNER DENVER®
Experience Proven Results

FEATURES

1 RELIABLE AND DURABLE AIR FLOW CONTROL COMPONENTS

- High quality inlet and purge valves feature air operated butterfly valves which offer high cycle life, resilient elastomeric seats for leak free service, low profile nickel plated disks offer low pressure drop, stem bushings ensure smooth operation, and no field lubrication required.
- Durable pneumatic actuators are isolated from the air stream and can't be contaminated by incoming moisture. The inlet valves are double acting rack and pinion and use air power to both open and close. A spring return holds the purge valves closed prior to start-up and upon loss of pressure protects the desiccant bed from outside contamination. Dual pistons offer a large control area, high torque, and a rapid response. Position indicator shows if valve is open or closed. Valves may also be operated manually.
- Pilot air is filtered by a 1 micron particulate filter to ensure dependable actuation. An isolation valve allows for easy filter element service. Non-lubricated pilot valves with hermetically sealed coils and ISO 5211/Namur interface are standard.
- Check valves are soft seated for sure closures and minimal wear. Check valves are spring loaded to prevent back flow leakage when the downstream (closing) pressure is low.
- Separate depressurization valves allow slow depressurization of the off-stream tower. Mufflers keep noise below OSHA requirements.
- Repressurization valve allows tower to be fully repressurized before switchover which eliminates bed movement and loss of pressure downstream.

2 DURABLE AND EFFICIENT BLOWER

- High quality blowers
- Intake filter protects blower and desiccant beds from contamination
- Mounting pads and flexible air connections are used to eliminate vibration

3 HEATER DESIGN FOR LONG LIFE

- Low watt density (23 W/in²) elements with Incoloy sheaths
- Temperature is controlled by an adjustable, digital indicating controller with thermocouple input which minimizes temperature swings
- Protection against overheating and element burnout provided by hi-limit provisions on controller plus an overtemperature thermocouple
- Over current protector with manual reset is provided

4 INSULATION REDUCES HEATER SIZE

- Fully insulated heater vessel and upper purge piping standard
- Minimizes heat losses which reduces heater size
- Protects plant personnel from hot surfaces
- Durable melamine foam and fiberglass protected by jacket of polyester fabric impregnated with PVC

5 LARGE DESICCANT BEDS ENSURE CONSISTENT DEW POINTS

- 30% extra desiccant provided to compensate for natural bed aging over the expected 3 to 5 years bed life
- 7.2 seconds of contact time for saturated air with the desiccant.
- High grade of activated alumina has high crush strength and is resistant to abrasion

6 QUALITY TOWER DESIGN

- Cleanable, stainless steel air flow diffusers on inlet and outlet ensure even flow distribution and eliminate channeling through the bed
- Separate fill and drain ports
- ASME code constructed and stamped pressure vessels standard.
- Pressure relief valves on all models
- Finished with heat resistant enamel



PROCESS DESIGNS

The DPB Series process design offers the end user the opportunities to significantly reduce the energy costs associated with achieving a reliable -40°F (-40°C) pressure dew point. This is achieved by eliminating or reducing purge air requirements (compressed air utilized to regenerate desiccant beds) typical of other desiccant dryer designs.

STANDARD AIR DRYING AND FILTERING PROCESS

- Compressed air is prefiltered prior to the desiccant dryer by a 1 micron solid particle particulate filter and then by a oil removal filter [to 0.008 ppm (0.01 mg/m^3)].
- The wet, compressed air now enters the bottom of Tower 2 of the two dual towers filled with a bed of activated alumina desiccant through the inlet switching valve A. Inlet switching valve B is closed. Inlet valves A and B are butterfly valves with double acting actuators.
- The activated alumina adsorbs the moisture in the compressed air as the air flows upward through Tower 2. Upflow drying protects the bed from water and heavy contaminants by separating them from the air stream as they enter the tower. Cleanable, stainless steel, flow diffusers on the inlet and outlet of the tower ensure even flow distribution through the bed-which avoids channeling.
- The dry air exits the dryer through outlet check valve F. A FHT Series High Temperature afterfilter filters desiccant dust particles to 1 micron in size at the dryer outlet.

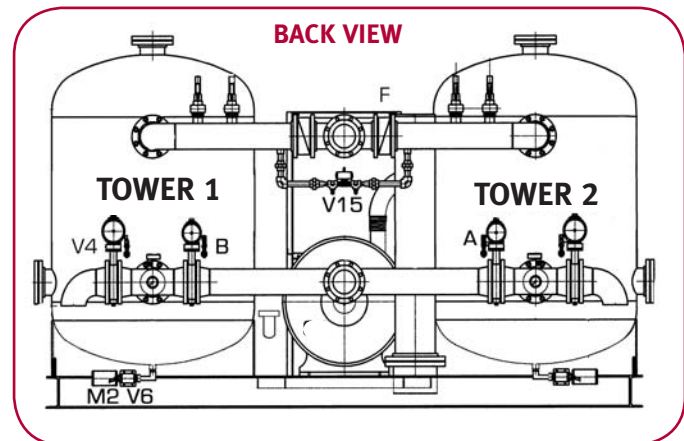

FEATURES, BENEFITS, OPTIONS

STANDARD CONTROLLER

- Tower Status
- Service Reminder
- Heater on
- Heater temperature
- Desiccant bed temperature
- Failure to switch
- RS 232 port
- NEMA 4 enclosure

OPTION E = ENERGY SAVING DEMAND CONTROLLER

- Energy saving demand controller provides an integrated humidity/temperature sensor from the on-line drying tower. Sensor “over-range” and “under-range” alarms. High humidity alarm.
- Vacuum fluorescent text, 2 line 16 characters. Highly visible in darkness or sunlight
- English, Spanish, French languages
- Automatic restart after power loss
- Remote indication of alarm
- Power on light
- Heater on light
- Tower status (drying, switchover, heat, cool, etc.)
- Tower switch switchover, failure (low heater temp/ high heater temp)

- Dry Contacts (power, heater-on)
- LED sensor over-range or under-range temp/ humidity dew point
- Service reminder
- RS 232 port
- NEMA4 enclosure

OPTION D = DEWPOINT MONITOR WITH ENERGY SAVING DEMAND CONTROLLER

- Digital dew point monitoring (text display)
- All of the features of the Energy Saving Demand Controller
- High dew point alarm

OPTION V

- Insulate vessel shell and hot piping from heater to vessels

OPTION F1

- Mounted Grade E prefilter and FHT afterfilter with drain valve on separate skid package.

OPTION F2

- Mounted Grade E prefilter and FHT afterfilter with drain valve with block and by-pass valves on separate skid package.

DHP Series Specifications

Model	Flow (scfm)	Heater Rated Output kW	Blower hp	Dimensions h x w x l	Weight (lbs)	In/Out Connections	Repl. Desiccant (lb)
DPB0500	500	10	2.2	105 x 53 x 70	1866	2" NPT	354
DPB0600	600	12	3.4	108 x 55 x 71	2111	2" NPT	453
DPB0750	750	14	2.9	114 x 60 x 83	2456	3" ANSI Flg	590
DPB0900	900	16	2.7	114 x 60 x 83	2472	3" ANSI Flg	590
DPB1050	1050	19	3.7	113 x 64 x 84	2981	3" ANSI Flg	710
DPB1300	1300	23	7.1	118 x 66 x 85	3576	3" ANSI Flg	923
DPB1500	1500	28	10.1	116 x 80 x 93	5359	3" ANSI Flg	1259
DPB1800	1800	32	9.4	116 x 80 x 93	5359	3" ANSI Flg	1259
DPB2200	2200	39	7.5	124 x 85 x 104	8018	4" ANSI Flg	1867
DPB2600	2600	45	13.9	124 x 85 x 104	8123	4" ANSI Flg	1867
DPB 3200	3200	53	11.1	121 x 97 x 117	9333	6" ANSI Flg	2377
DPB3600	3600	58	5.4	128 x 97 x 117	9833	6" ANSI Flg	2610
DPB4300	4300	70	5.9	124 x 105 x 130	12350	6" ANSI Flg	3398

Table 1

Pressure PSIG (KGF/CM ²)	Inlet Temperature °F (°C)						
	60 (15.6)	70 (21.1)	80 (26.7)	90 (32.2)	100 (37.8)	110 (43.3)	120 (48.9)
60 (4.2)	1.03	1.01	0.99	0.80	0.58	0.43	0.32
70 (4.9)	1.10	1.08	1.07	0.94	0.68	0.50	0.37
80 (5.6)	1.17	1.15	1.14	1.08	0.79	0.58	0.43
90 (6.3)	1.24	1.22	1.20	1.18	0.89	0.66	0.49
100 (7.0)	1.30	1.28	1.26	1.24	1.00	0.74	0.55
110 (7.7)	1.36	1.34	1.32	1.30	1.11	0.82	0.61
120 (8.4)	1.42	1.40	1.38	1.36	1.22	0.90	0.67
130 (9.1)	1.48	1.46	1.44	1.42	1.33	0.99	0.74
140 (9.8)	1.53	1.51	1.49	1.47	1.44	1.07	0.80
150 (10.6)	1.58	1.56	1.54	1.52	1.50	1.16	0.87

WARRANTY
ONE YEAR
PARTS
AND
LABOR

OPERATING PARAMETERS

- Maximum working pressure: 150 psig
- Minimum working pressure: 60 psig
- Inlet air: 100 ±2 psig at 100°F ±2°F
- Ambient temperature: 80°F ±5°F
- Ambient dew point temperature: 70°F
- Inlet pressure dew point: 100°F
- Outlet pressure dew point: -40°F (excluding bump at changeover)
- Maximum delta P: 5 psid
- Drying time: 4 hours
- Inlet air pressure: 60–150 psig
- Inlet air temperature: 40–120°F

Available voltages: 460V/3ph/60Hz, NEMA 4 enclosure

Non-standard conditions contact customer service.

NOTES:

Inlet Flow capacities have been established at an inlet pressure of 100 psig (7 kgf/cm²), and a saturated inlet temperature at 100°F (38°C). To determine maximum inlet flow at other conditions, multiply the inlet flow from the Specifications Table by the multiplier from Table 1 that corresponds to your operating conditions.

Dew Point: Outlet pressure dew point at rated inlet conditions of 100 psig (7 kgf/cm²) and 100°F (38°C) and 70°F (21°C) atmospheric dew point is -40°F (-40°C). Dew point varies slightly at other conditions. Consult factory to determine exact outlet pressure dew point at your operating conditions.

Outlet Temperature at normal rated conditions (after temperature spike) is 127°F (53°C). Outlet temperature varies depending on inlet temperature and pressure. Consult factory to determine exact outlet temperature at your operating conditions.



Gardner Denver®

For additional information contact your local representative or Gardner Denver Compressor Division, 1800 Gardner Expressway, Quincy, IL 62305
Customer Service Department Telephone: (800) 682-9868 FAX: (217) 221-8780
Sales and Service in all major cities.
www.gardnerdenver.com maggie@gardnerdenver.com

