

RES Series
90-675 SCFM
Cycling Refrigerated Dryer



GD
GARDNER DENVER

Experience Proven Results™

RES Value

Why consider a RES cycling dryer for your compressed air system?

ENERGY SAVINGS!

Non-cycling refrigerated air dryers operate with the refrigeration compressor running continuously, regardless of inlet load. Minimal energy savings is realized from 100% down to 0% inlet air load.

The RES Series air dryer automatically cycles the refrigeration compressor on and off in response to inlet load conditions. As the inlet air load is reduced, the refrigeration compressor cycles off, providing you with savings.

The load matching design saves energy and reduces your costs.



sav·ing [sey-ving]
-noun

1. a reduction or lessening of expenditure or outlay: a saving of 10 percent.
2. something that is saved.
3. savings, sums of money saved by economy and laid away.

en·er·gy [en-er-jee]
-noun

1. any source of usable power, as fossil fuel, electricity, or solar radiation.
2. the capacity for vigorous activity; available power.
3. Physics. the capacity to do work. Symbol: E

HARNESS ENERGY SAVINGS WITH GARDNER DENVER RES

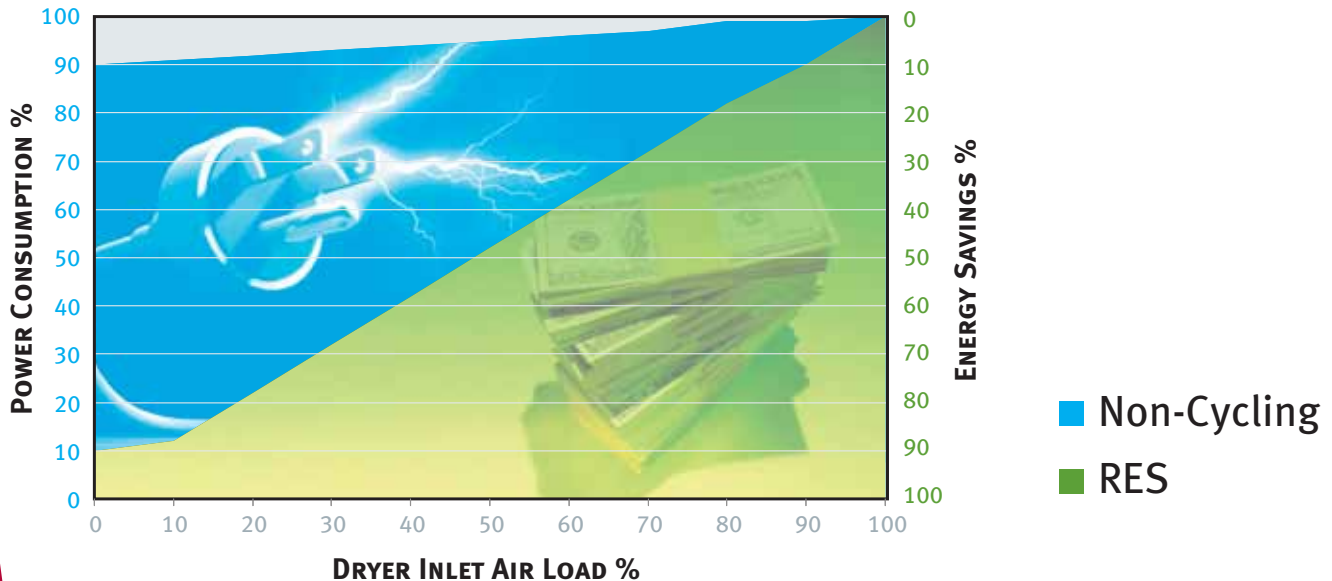

How does the *Gardner Denver RES* cycling dryer compare?

BUILT-IN AIR FILTRATION UNMATCHED IN THE INDUSTRY

- 1 – The standard dryer is equipped with a Grade B filter/separator
 - ISO Quality Class 3: Remaining solid particulate
 - ISO Quality Class 5: Remaining oil concentration
 - ISO Quality Class 5: Pressure dew point
- 2 – Optional Grade E high efficiency coalescing filters are available
 - ISO Quality Class 1: Remaining solid particulate
 - ISO Quality Class 1: Remaining oil concentration
 - ISO Quality Class 5: Pressure dew point

BENEFITS OF BUILT-IN FILTRATION

- Ease of installation
- Smaller total footprint
- Lower total installed cost

NO-AIR-LOSS CONDENSATE DRAIN STANDARD

REBATE ELIGIBILITY

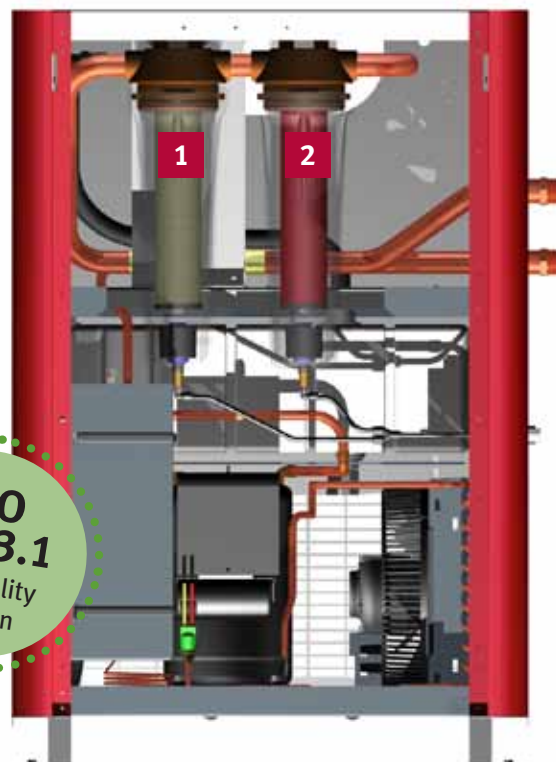

Premium WARRANTY

2 Years—Standard

3 Years—Extended

5 Years—Total

Parts and labor included. Contact your local distributor for more details.

RES Design

Innovation at Work

The Drying Process

COMPRESSED AIR CIRCUIT

1. Warm, saturated compressed air enters the dryer through the inlet pipe connection.
2. Air travels through the air-to-air heat exchanger and the glycol-to-air heat exchanger. Propylene glycol surrounds the passages and cools the air to the desired pressure dew point.
3. Moisture, solid particulates and oil aerosols are removed by the filter/separator. A no-air-loss condensate drain discharges contaminants from the system.
4. Dry, filtered air exits the dryer for use.

The Cooling Process

GLYCOL CIRCUIT

5. Glycol exits the air-to-glycol heat exchanger and then enters the glycol storage tank.
6. A circulation pump continuously moves the thermal medium throughout the circuit.
7. A thermal sensor monitors the glycol temperature and turns the refrigeration compressor off whenever the glycol is cooled to its lowest temperature. The cooling medium continues to dry the air. After the medium warms up, the thermal sensor restarts the refrigeration compressor.
8. The glycol-to-refrigerant heat exchanger chills the thermal media and travels back to the air-to-glycol heat exchanger.





Features

OPTIMIZED CABINET DESIGN

- Promotes ease of access from all four sides
- Certified to CSA C22.2 No. 236-05 / UL 1995

STAINLESS STEEL BRAZED PLATE HEAT EXCHANGERS

- Compact, thermally efficient
- Ensures delivery of an ISO 8573.1: 2009 Air Quality Class 5 pressure dew point

INTEGRAL FILTRATION

- Standard Filter/Separator removes solids down to 3.0 microns and oil aerosols to 5.0 mg/m³
- Optional Cold Coalescer removes solids down to 0.01 microns and oil aerosols to < 0.01 mg/m³

NO AIR LOSS CONDENSATE DRAINS

*STANDARD ON ALL MODELS

- Mechanical float drain is standard on models 90–140 scfm (153–238 nm³/h)
- Electric demand drain is standard on models 190–675 scfm (323–1148 nm³/h)

HERMETICALLY SEALED REFRIGERANT COMPRESSOR

- Environmentally friendly R-134a refrigerant
- High reliability, long service life

RUGGED GLYCOL RESERVOIR

- Stores food-grade propylene glycol cooling media
- Leak-free, rotational molded construction

RELIABLE THERMAL MEDIA CIRCULATION PUMP

- Continuously moves cooling medium through the dryer
- Cartridge design promotes reliability and ease of service

RES Specifications

Model	Rated Flow ¹		Voltages	Power	In/Out Connection ²	Dimensions						Weight		Std Dp ³ Grade B		Opt Dp ⁴ Grade E	
	scfm	nm ³ /h				H		W		D		lbs	kg	psig	bar	psig	bar
			V/ph/Hz	kW	NPT	in	mm	in	mm	in	mm						
RES90	90	153	100/1/50	0.9	1.0"	38	965	29	737	20	508	249	109	2.8	0.2	4.0	0.3
RES120	120	204	115/1/60	1.2	1.0"	38	965	29	737	20	508	258	117	3.7	0.3	5.0	0.3
RES140	140	238	208-230/1/60	1.3	1.0"	38	965	29	737	20	508	263	119	4.0	0.3	5.5	0.4
RES190	190	323	220-240/1/50	1.3	1.5"	39	991	34	864	32	813	408	185	3.8	0.2	4.6	0.3
RES240	240	407		1.9	1.5"	39	991	34	864	32	813	478	217	4.2	0.3	6.0	0.4
RES280	280	476	208-230/3/60	1.9	1.5"	46	1168	35	889	32	813	497	225	4.3	0.3	5.7	0.4
RES360	360	612	380-420/3/50	2.0	2.0"	46	1168	35	889	32	813	540	244	3.9	0.2	4.1	0.3
RES450	450	765	460/3/60	2.6	2.5"	58	1473	32	813	42	1067	708	321	3.9	0.2	4.9	0.3
RES540	540	917	575/3/60	3.0	2.5"	58	1473	32	813	42	1067	793	360	3.8	0.3	5.3	0.4
RES675	675	1147		4.3	2.5"	58	1473	32	813	42	1067	844	382	4.9	0.3	6.6	0.5

1 Rated Flow Capacity - Conditions for rating dryers are in accordance with ISO 7183 (option A2) working conditions: inlet air temperature 100° F (38° C), inlet air pressure 100 psig (6.9 bar), ambient air temperature 100° F (38° C), 100% saturated air, operating on 60 Hz power supply.

2 BSP connections available

3 Pressure drop inclusive of integral filtration

4 Cumulative pressure drop includes Grade B and Grade E filter/separator elements

Flow Model		Max. Working Pressure (Float Drain)		Max. Working Pressure (Electric Drain)		Min. Working Pressure		Max. Inlet Air Temperature		Min. Inlet Air Temperature		Max. Ambient Air Temperature		Min. Ambient Air Temperature	
scfm	nm ³ /h	psig	bar	psig	bar	psig	bar	° F	° C	° F	° C	° F	° C	° F	° C
90–140	153–238	250	17.2	–	–	30	2.1	130	54	40	4	110	43	40	4
140–675	204–1147	–	–	232	16.0	30	2.1	130	54	40	4	110	43	40	4



RES Series Options

- Level II Advanced Electronic Controls (models 190–675 scfm)
- Cold coalescing separator elements
- Water-cooled condensing unit (models 190–675 scfm)
- 3 valve block and by-pass
- Four gauge package (panel mounted)

Two Levels of Control

STANDARD LEVEL I (RES90–RES675)

Easy to monitor controls provide dryer status

- Dryer on/off switch
- Dryer on light
- Thermal medium temperature
- Dryer energized (RES190–RES675)
- Compressor on light

OPTIONAL LEVEL II (RES190–RES675)

RES Series Level II microprocessor controller

- Operator Interface Displays:
 - » Date/time/operating status
 - » Hours to service
 - » Total compressor operating time
- Energy Savings Interface:
 - » Daily average load
 - » Monthly average load
 - » Annualized energy savings in dollars or euros
 - » Scheduler mode for automatic start/stop operation

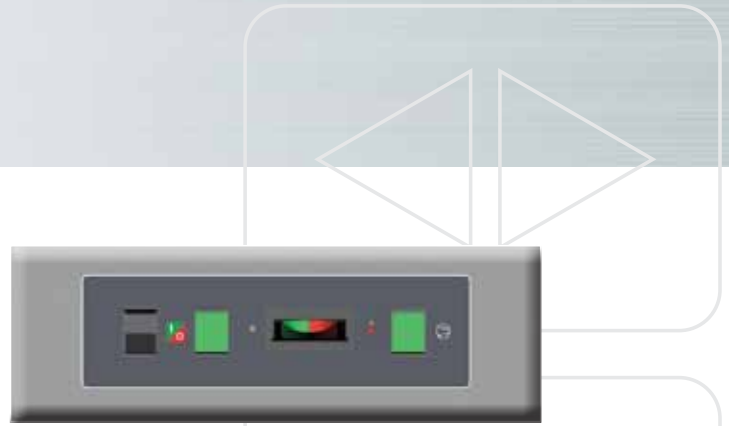

Standard Level I (RES90–RES140)



Standard Level I (RES190–RES675)



Optional Level II (RES190–RES675)

Capacity Correction Factors

Inlet Pressure		Inlet Temperature					
		80° F	90° F	100° F	110° F	120° F	130° F
psig	bar	27° C	32° C	38° C	43° C	49° C	54° C
30	2.1	1.24	0.92	0.71	0.56	0.44	0.35
50	3.4	1.40	1.07	0.83	0.66	0.54	0.44
80	5.6	1.55	1.19	0.95	0.77	0.63	0.52
100	6.9	1.61	1.25	1.00	0.82	0.68	0.56
125	8.6	1.67	1.30	1.05	0.86	0.72	0.61
150	10.3	1.71	1.34	1.08	0.90	0.75	0.64
175	12.1	1.75	1.37	1.11	0.92	0.78	0.66
200	13.8	1.77	1.39	1.14	0.95	0.80	0.68
250	17.2	1.81	1.43	1.17	0.98	0.83	0.72

Correction Factors for Ambient Temperature*

Ambient Temperature	80° F	90° F	100° F	110° F
	27° C	32° C	38° C	43° C
Multiplier	1.12	1.06	1.00	0.94

*Air-cooled models only.
For water-cooled use a 1.15 multiplier if cooling water is less than 95° F (35° C).

Standards per ISO 8573.1

Quality Classes	Solid Contaminants (maximum particle size in microns)	Maximum Pressure Dew Points		Maximum Oil Content (droplets, aerosols, and vapor ppm)	
		° F	° C	w/w	mg/m ³
0	as specified	as specified		as specified	
1	0.1	-94	-70	0.008	0,01
2	1	-40	-40	0.08	0,1
3	5	-4	-20	0.8	1
4	15	38	3	4	5
5	40	45	7	21	25
6	–	50	10	–	–

Aftermarket Parts, Lubricants & Remanufactured Airends



PROTECT THE INVESTMENT IN GARDNER DENVER

Regular maintenance and service of Gardner Denver product is critical to the performance and longevity of the equipment. Only Gardner Denver can provide the assurance that the investment will provide a lifetime of productivity.

RELIABILITY

Only Gardner Denver can provide aftermarket parts and services that are engineered for use in Gardner Denver products. The parts and lubricant have been tested under rigorous conditions at the factory to the highest quality standards.

PERFORMANCE

Only Gardner Denver can provide aftermarket parts designed specifically for the Gardner Denver product. Use of OEM parts ensures that the investment in Gardner Denver will continue to perform year in and year out with the same reliability and efficiency.



EASE OF DOING BUSINESS

Only Gardner Denver can provide the peace of mind of turning to one supplier and one source for all aftermarket needs. Gardner Denver has the support network in place to handle all customer service, service and technical support needs.

VALUE

Only Gardner Denver can provide the high quality aftermarket parts and services for the life of the investment in Gardner Denver. Proper care of the Gardner Denver product is vital to the equipment's performance and efficiency. Lean on a trusted source — Gardner Denver.



Gardner Denver®

www.GardnerDenverProducts.com

Gardner Denver, Inc. 1800 Gardner Expressway, Quincy, IL 62305
www.contactgd.com/compressors
866-440-6241

©2013 Gardner Denver, Inc. Printed in U.S.A. GA-RES-100 1st Ed. 7/13

